

THE WINDWORD

Calendar

- Feb. 9** BOG Meeting
- Feb. 14** Valentine's Day
- Feb. 18** General Racing Meeting
- Feb. 20** President's Day

Officers

- COMMODORE**
Ginger Brownre.brown@mac.com 2018
- VICE COMMODORE**
Charlie Volkvolkcj@cox.net 2019
- REAR COMMODORE**
Tim Millertimmiller2@cox.net 2017
- TREASURER**
Paul Schyep.e.schye@gmail.com 2016
- SECRETARY**
Ardie Condonardiec27@gmail.com 2018
- BOARD MEMBERS**
Deann Gadalladeanngadalla@yahoo.com 2019
Blaine Van Damvandamb@cox.net 2017
Brian Hakalabhakala@mac.com 2017
Steve Kubinskubinova@cox.net 2019
- NEWSLETTER EDITOR / WEBMASTER**
Jennifer Pasternakjpasternak@wvsailing.com

Committee Chairs

- | | |
|---|------------------------|
| BOARD LIAISON | COMMITTEE CHAIR |
| ACTIVITIES CENTER
Steve KubinGene Plehal | |
| ARCHIVIST
Tim MillerDavid Reynolds | |
| BUILDING AND GROUNDS
Paul SchyeJohn McCabe | |
| CALLING
Ardie CondonJulie Barth | |
| CLUB POWERBOAT MAINTENANCE
Blaine Van DamTBD | |
| DRY-STORAGE
Paul SchyeJim Smith | |
| FINANCE
Paul SchyeKathy Malcolm | |
| GOVERNMENT RELATIONS
Blaine Van DamGene Nold | |
| HARBOR
Paul SchyeGene Nold/Dave Bonifield | |
| LONG RANGE PLANNING
Charlie Volk, Tim Miller, Ed Webb +2 | |
| MEMBERSHIP
Ardie CondonArdie Condon | |
| NEWSLETTER AND WEB
Tim MillerJenn Pasternak | |
| PUBLIC RELATIONS
Tim Miller and Deann Gadalla | |
| RACING ACTIVITIES
Blaine Van DamRob Brown | |
| SAFETY, TRAINING & EDUCATIONAL PROGRAM
Deann GadallaGary Pierce | |
| SAILING PROGRAM
Brian HakalaGlenn Bindley | |
| SECURITY
Brian HakalaBrian Hakala | |
| SOCIAL
OpenTBD | |

The Newsletter of the Walnut Valley Sailing Club

www.wvsailing.com

From the Commodore

Ginger Brown

As I write this there are 55 days left until spring is upon us. After having spent 20+ years in Kansas, I know that there is no guarantee that we will actually experience weather balmy enough to get out and enjoy the lake on our boats, but hope springs eternal....

As you all know, our club's work is mainly done by volunteer labor. To date we have filled most of the committee chairs, but not the Hospitality Chair. The board is moving ahead making plans for spring and summer festivities. At present, we are hoping to get individual groups to sponsor a social; we have three planned so far. We generally have at least three more. So talk to your friends, check the calendar and plan a party! But, it would still be great to have someone take responsibility for organizing everyone. If you haven't held a volunteer position at the club before, this might be a good time to consider doing your part. No particular skills are required, just a desire to promote good fellowship and club spirit.

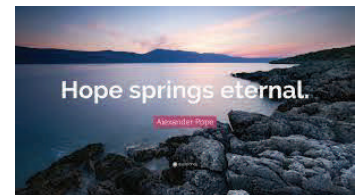

Plans are also under way for our Anniversary Celebration. There has been talk of an Invitational Regatta; I think it would be great to be able to invite clubs from the neighboring states to help us celebrate our 80th Anniversary. However, to pull this off will require participation from the entire club. Cheryl Wertheimer has graciously agreed to take the lead in planning our celebration, but is in need of lots of help. Please contact her if you are able to assist in any way, 316.733.2685.

Welcome New Members:

Donald and Merilyn Harris from Wichita
Owners of a Catalina 30 - "ONE MORE DAY"

WVSC SAILORS:

Racing is a great way to improve your sailing skills.

Join us in designing a racing season that will encourage participation and provide a fun environment for sailboat racing in 2017.

Our general racing meeting will be held on Saturday, February 18th, from 3 pm to 4 pm at the Brown's home:
3220 N 143rd Street E, Wichita, KS 67228.

We encourage anyone who is interested in participating in the 2017 season to attend.

This is not only for hardcore racers!

If you are a competitive racer, are curious about how to make sailboats go faster, or if you have an interest in the race committee, we would like to hear from you.

Agenda:

- 1) Race Schedule
- 2) Scoring
- 3) Courses
- 4) Race Committee

If you can't attend, but have ideas on what you would like to see in this season's racing program, please contact Rob Brown.

Dillons Community Rewards—Support S.T.E.P.

The STEP / Jr. Sailing Program would like to thank all of the members that have taken the time to register their Dillons' shopper cards for cash donations from Dillons. When shoppers register their cards, our STEP program receives a portion of the money that Dillons gives to community organizations.

We received our first quarter payout for **\$54.95** from eleven people who registered their Dillons' cards. We encourage all members to sign up, as well as family and friends.

The organization name is "Walnut Valley Sailing Club - Youth Sailing," and our number is 45766.

This is a great way to help our STEP program, and the link is on the main page of our club's website.

In addition, shoppers still can acquire fuel points - registering your card **does not affect** your fuel points at all.

Please consider registering your Dillons' card to support WVSC Youth Sailing

WVSC's Own Chris Collins Shares his Expertise:

Electricity for Sailors – #3 Charging & Starting Systems ~ Part Two

Testing a Manual Battery Charger: Connect a voltmeter across the battery and take a reading. If fully charged, it will read about 12.6 V or greater. Connect the manual (non-automatic) charger and turn it on. Take another voltage reading. The voltage must be greater than the battery voltage for charging to occur. The voltage is not regulated on a manual charger. If the charger has an ammeter, you can watch the amps drop and the voltage climb as the battery becomes fully charged.

My experience has been that the voltage maxes out around 15.3 V with the battery boiling and getting hot. The manual charger should be turned off before excessive gassing or heating occurs. I turn mine off just before the voltage approaches 15 volts. Use judgement as your charger might charge faster and cause excessive gassing at an earlier voltage.

If overcharging is permitted, a manual charger can cook a battery. The smell of a battery cooking is often described as “sulfur” or “rotten eggs”. Not only does it smell bad, it is not good for the battery.

Testing an Automatic Battery Charger: Connect a voltmeter across the battery and take a reading. If fully charged, it will read about 12.6 V or greater. Connect the automatic battery charger and turn it on. Take another voltage reading. The voltage must be greater than the battery voltage for charging to occur. The voltage is partially regulated on an automatic charger. If the charger has an ammeter, you can watch the amps drop and the voltage climb as the battery becomes fully charged.

A correctly functioning automatic charger will shut off when the voltage climbs to a specified voltage. The voltage will creep down and the charger will turn back on. Initially, this cycle might be rapid. As the battery becomes charged, the charger will remain off for extended periods. Some automatic chargers will shift into a “float” mode. A tiny current is used to closely maintain a set voltage across the battery.

Testing Generators & Alternators: Many years ago, vehicles had generators. Perhaps an older boat might still have a generator. Modern engines are equipped with alternators. Alternators are more efficient than generators. For our purposes both devices charge the battery and they both have voltage regulation. Don't forget to make sure the alternator belt is tight! A loose belt can sometimes slip without making noise. A slipping belt can reduce charging.

Connect a voltmeter across the battery and take a reading. If fully charged, it will read about 12.6 V or greater. Start the engine. Take another voltage reading. The voltage must be greater than the battery voltage for charging to occur. The voltage is regulated. When functioning correctly, the voltage will probably slowly climb and then become steady somewhere between 13.5 V and 14.5 V.

Since the voltage is regulated and the battery resistance changes with the state of charge, the charging current will initially be high and then drop off to near zero as the battery is fully charged. The voltage should remain steady in the 13.5 – 14.5 V range. A higher reading will cause more battery gassing and water loss. A lower reading will charge at a slower rate or fail to charge.

Alternator & Generator Repair: If you start the engine and the voltage does not steady out in the 13.5 V – 14.5 V range, then you most likely have a charging system problem. Check and adjust the belt first. If there will be a delay with the repair, charge the battery with a manual or automatic charger so it does not become sulfated.

(Continued on Page 4)



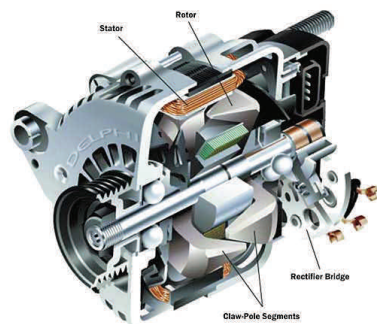

(continued from Page 3, *Electricity for Sailors*, Chris Collins)

If your alternator has an external voltage regulator, you might experiment by replacing the voltage regulator. If that does not solve the problem, you will need a professional to rebuild/repair the alternator. Remove the alternator and take it to a shop that specializes in alternator and starter overhauls. I don't like exchanging alternators or starters at the parts store. I prefer to get mine rebuilt and/or tested by an expert who can provide feedback and answer questions.

Voltmeter or Ammeter: If I can have only one meter on my engine instrument panel, it will be a voltmeter. An ammeter and voltmeter would be ideal. An ammeter usually shows a charge for a brief period after an engine is started. Then it drops back to zero providing no valuable information. A voltmeter will tell you if the charging system is maintaining the proper voltage. If the voltage is good (13.5 V – 14.5 V), and the battery is not defective, it is charging correctly! Every time you look at the voltmeter, you are monitoring the charging system. You can't say that for an ammeter that zeros out after the first few minutes. Note, this also depends on how the ammeter is wired in the circuit.

Voltmeter connection: For the next test, you will insert the voltmeter so any electrons that flow through the battery must flow through the meter. Remove one of the cables from the battery post. Connect one lead of the voltmeter to the battery post and the other voltmeter lead to the cable. This is the same way you would connect an ammeter if you were wanting a correct reading on the current flow. The meter is inserted in the circuit.

Testing for a Slow Drain on the Battery: Perhaps everything checks well but the battery keeps running down when you leave the boat for a few days or weeks. You might have something that is slowly drawing current. This could be a radio, clock, or some other device that is not normally turned off. With all switches/breakers turned off, disconnect one side of the battery and insert a voltmeter between the battery post and the wire/cable you just disconnected. I prefer an analog voltmeter for this test. If the reading is less than full battery voltage, you probably don't have enough drain to worry about.



If the reading is full battery voltage, you will need to find the culprit that is draining the battery. If you like, you can insert an ammeter between the battery post and the wire/cable you disconnected. This will provide you with the true amount of current draw. That number might be fun to know. Be careful as most multi-meters read only small currents and the meter could be damaged if you exceed this value. It is safer to connect a voltmeter in the circuit just like you would an ammeter. The voltmeter simply tells you there is a complete circuit back to the battery. I.e. if a light bulb were switched on, the filament in the bulb would complete the circuit and the voltmeter will read full or nearly battery voltage. The voltmeter will not be damaged no matter what you turn on.

Finding a drain is usually a pain. Start with what is easy or suspicious. If you have fuses, disconnect them one at a time, watching the voltmeter to see if the drain stops. If you remove a fuse, for instance, that stops the drain, explore what is connected to that fuse. If any accessory is connected directly to the battery, disconnect that accessory and see if the drain disappears. If there is a clock in your stereo that runs all the time, disconnect the stereo and re-test. Clocks work great in a vehicle that we drive daily but will run a battery down if left for extended periods.



Look for part 3, the final chapter in

Electricity for Sailors – #3 Charging & Starting Systems

in the March 2017 WindWord.

Thank You to Chris Collins for his continuing contributions of Electricity for Sailors articles for the WVSC WindWord

1978 Catalina 30'

Standard Rig fin keel This is a solid boat that doesn't look its age. The bottom is smooth with no blisters and no Catalina "smile." It is fast, and has been very competitive in club racing at both Cheney & El Dorado lakes. Wheel steering, huge bimini covers entire cockpit, Atomic 4 gasoline engine, runs well, starts easy, Stern gate with ladder, & seats on stern rail, Garhauer mainsail cabin-top traveler conversion, North Dacron Main and 155 Genoa—about 8 years old & in good condition, very heavy duty Genoa blocks—good for racing with large genoa, large 2 speed self-tailing Genoa winches, halyards led to cockpit with Garhauer rope clutches on cabin top, Sailrite mainsail "stack pack" cover—easy to raise & lower mainsail, & cover it, Garhauer ball bearing masthead sheave—for ease of raising & lowering sails, Harken code 1 furler - has 2 foil grooves, & can be converted easily for changing sails while racing, recovered upholstery cockpit cushions, Garmin 431S chartplotter—has sonar and depth feature, 4 inch screen, Raritan head, just rebuilt, Trailer with keel guides for ramp loading.

Sailboat is on trailer in WVSC yard, asking **\$17,500**. Please contact Alan Loehr at 316.648.8188

1985 Hunter 23'

\$2499 OBO, Swing keel, good condition, with lots of extras: loose footed Main (2014) with two reef points, 135 Genoa (2014) on an Alado roller-furler, sail covers, tiller-tamer, 8 hp 2-stroke Tohatsu, AM/FM CD player with speakers, Piranha depth/fish finder, whisker pole and trailer. New bottom Paint. A nice sailing sloop, can be used as a day sailer. Moving away from the area Slip# A20, El Dorado Lake.

Please contact Brad Oblak at 316.841.2815, bkoblak@gmail.com

Catalina 27

18 HP inboard diesel, with sails and whisker pole, in decent shape. The motor runs well, the mast needs some new pulleys at the top.

It includes all items currently on it, including life jackets (does not include tool set). Asking **\$8,000**.

Please contact Matt Nicks at 316.841.3078 or mnicks78@gmail.com

Hydrohoist

6000 model boat lift for sale, 6000 pounds capacity, in good condition, **\$1200 OBO**. Please contact Ed Webb

Starfish

14 ft w/trailer and accessory mast carrier, **\$300**.

Please contact John Rigenbach at 316.788.1053

Cruising Spinnaker for Precision 21

Or similar boats with dimensions close to I:22 7' and J:7 0'. Sail is new in bag. I bought it for my Holder 20, but have decided not to use it.

Asking **\$150 00**, what I paid for it, or will consider an interesting trade.

Please contact Sid Rousseau at 316.722.8983

Cal 21" with Trailer

Currently in dry storage at WVSC, only **\$900**

Please contact Don Bland 316.208.7371

Catalina 22

On trailer.

Please contact John at 316.722.4356

Catalina 25 1985

Swing Keel, trailer, 2003 Nissan 9 8 outboard. Good main, front sail on roller furling. Can see at El Dorado Lake, **\$7,000**.

Please contact Bruce Ward at 316-250-4479 or bruce@brucewardphotos.com



WVSC STEP Program Items for Sale

- Capri 22 Spinnaker New, **\$700**
- Spinnaker, used, **\$625**
- Lewmar Winch, **\$193**
- 110% Jib for Capri 22 (?), **\$620**
- Catalina 22 Main, **\$495**
- Spinnaker pole, 8' 2", 2" dia (New), **\$500**
- Whisker pole, 6'6"-12' extender twist lock, **\$300**
- Whisker Pole, 10'5"-17'5" extender, 2" dia. Line extender, **\$700**

- Tack Tick, **\$350**

- Hydrohoist Tanks 24" diameter 23' long, **\$2,000**

- New Life Jackets, **\$25 ea**

- 2" receiver hitches, **\$9 ea**

Please contact Gary Pierce 316.686.8823 Pierce, gpiercewich@cox.net or Gene Nold, 316.734.3981, genenold@att.net

1983 Gloucester, 23'

In very good condition, comes with galvanized trailer. It has a shoal keel with a swing center board. Mercury 9 hp motor with very few hours. The main was reconditioned with very little sail time. New sail covers at the same time. The halyards and dock lines were new in 2014. Sailboat can be seen at Walnut Valley Sailing Club, asking **\$5,500**.

Please contact Ed Klima at 620.786.5146

2HP Outboard Motor

Long shaft, excellent condition, **\$225** Will demo!

Please contact John McCabe at 316.644.8344

Cal 21" with Trailer

Currently in dry storage at WVSC, only **\$900**

Please contact Don Bland 316.208.7371

Sail Fish/Sun Fish Clone

Virtually identical to the Sun Fish. This boat is very seaworthy, all new paint on bottom and all wooden parts recently varnished. New main sail control, all new mast and boom caps. The boat comes with new, high dollar, multi-color sail and a quality white window racing sail, new snap on sail rings. Dagger board and kick up rudder with tiller extension, all lines included, ready for the lake. No trailer. **\$650**.

Please contact Ed Harned at 316.640.7148



THE WINDWORD



Walnut Valley Sailing Club

Board of Governors Meeting

Thursday, Jan. 12th, 2016 * 7pm. * Commodore's House - 3220 N. 143rd St. East, Wichita, KS
Minutes Subject to Change

1. Call to Order: 7:00 pm

BOG Members: Ginger Brown, Charlie Volk, Tim Miller, Blaine Van Dam, Paul Schye, Steve Kubin, Deann Gadalla, Ardie Condon, Brian Hakala

Guest Members: David Bonifield, Gene Nold, Gene Plehal, Jim Smith

2. Commodore's Remarks:

Ginger received a request from a WVSC member to host the "Family Day for Flight Safety." The member said some of the employees have shown interest in the sport. The activities would include having WVSC members take interested persons/family for a sail. The Board feels this would be good PR and possibly encourage new STEP students and new members for the club. The Board will pursue this request.

3. December BOG Minutes: Minutes Approved

4. The 2016 Annual Meeting Minutes, Nov. 5, 2016: Minutes Approved

5. Member's Concerns: None

6. Liaison Reports:

Membership - Ardie: We have 6 members that have resigned this year.

Activity Center - Steve: Needed supplies are being purchased in preparation for sailing season. There is a search for professionals to take over cleaning the center. Thank you to Randy, for volunteering the last few years to personally clean the activity center – he did an excellent job.

Racing - Blaine: Rob Brown will call racing meeting in near future.

Long Range Planning - Charlie: Added 4th member to committee.

Social: Discussion of WVSC 80th Birthday. Need volunteers to help with possible April date for celebration and Regatta later in the season.

Finance – Paul: Distributed the monthly financial reports for month ending 12/31/2017. Motion to approve application for new membership from Donald and Marilyn Harris was approved. Five members are late with yearly dues. Motion was made and approved to waive the 10% fee for late payment for 2017.

Powerboat - Blaine: Position of Committee chair to maintain powerboat is still open.

Buildings, Grounds, & Dry Storage: Nothing to report

Harbor - Paul: Travel Lift - Committee working on financial feasibility plan before it is decided if special meeting of the club will be in order. Charlie submitted detailed outline of questions that members may have, to help in the preparation of presentation at a special meeting.

Sailing Activities - Brian: Glen Bindley has volunteered to chair the Sailing Activities committee for approval of the BOG at next meeting.

Security - Brian: Nothing to report

PR – Tim: Nothing to report

Archive - Tim: Nothing to report

STEP - Deann: STEP has received 2 boat donations, a Catalina 22 and a Boston Whaler.

Eleven people have signed up their Dillons' cards for donation of \$54.95 for the first 3 months. If anyone has not signed up for this "free" money...please consider it. The link is found on the WVSC website. It does not affect your fuel rewards!

Two items sold at silent auction at the Christmas Party raised \$95.

Government Relations - Blaine Nothing to report

7. Old Business:

At the December meeting, a member expressed interest in having campsites on the property for members and their families to stay overnight on weekends. Gene Nold checked on this and reported it is prohibited in our Concierge License at this time. It was agreed by the Board to move forward to pursue options that might be acceptable with the state.

We are waiting to get bid from local company for making a cover for the power boat. We will compare it with a price we received from a company in Texas.

8. New Business:

Request to host "Family Day for Flight Safety." Covered above

9. Move to Adjourn: Meeting adjourned 9:10pm.

10. Next Meeting: 7:00 pm on February 9th, 2017 at the home of Ginger Brown: 3220 N. 143rd St. East.

The minutes of the 2016 Annual Meeting are below. Full Committee Reports, two additional reference documents and three financial statements are posted on the website @ www.wvsailing.com

Walnut Valley Sailing Club

2016 Annual Meeting Minutes

Saturday, November 5, 2016, 6:30 pm

House of Schwann

3636 N Comotara, Wichita, KS

Reference Documents (2):

- (1) WVSC Annual Meeting package distributed to club membership, including:
 - Parliamentary Rules of Debate
 - Annual Meeting Agenda
 - 2015 Annual Meeting Minutes
 - Treasurer's Report, with 2016 Annual Report and proposed 2017 Budget
 - STEP Treasurer's Report, with 2016 Annual Report and proposed 2017 Budget
 - Board of Governors Nominee Biographies
 - Committee Reports
 - Treasurer's Report, with 2015 Annual Report and proposed 2016 Budget
 - STEP Treasurer's Report, with 2015 Annual Report and proposed 2016 Budget
 - WVSC Annual Awards
- (2) Dry Storage Area Boat Hoist Concept (submitted by Jim Smith)

Annual Meeting Called to Order, 6:32 pm, 5 Nov 2016, by Commodore Miller

Opening Remarks: Commodore Miller welcomed club members to our Annual Meeting. Commodore thanked our Club's outgoing Board Members for their service: Cheryl Wertheimer, Brad Oblak, and Gerri McFadden. A short year summary included:

- Clubhouse renovation (interior and exterior)
- Interesting and varied Sailing activities
- Competitive and well run racing season
- STEP Youth Training expansion

Commodore Miller reminded us of our impending 80th Anniversary celebration in 2017, and that Cheryl Wertheimer will lead our Club's activities.

Commodore Miller then outlined the meeting procedures, including the voting procedures.

Agenda: Commodore Miller requested the membership's approval to adopt the agenda in the meeting package distributed at the door (Reference 1). *"Ayes" carried. Change to agenda adopted.*

Speaking and Voting Rights: Due to a change in our Club's By Laws, only club members with paid in full 2017 dues will be able to vote. Commodore Miller requested concurrence from the membership that any club member present at the meeting, however, be permitted to address the meeting. *Commodore Miller asked if there are any objections to recognizing any club member to speak on a motion. No objections noted. Hearing no objections, it is so ordered.*

Debate: Commodore Miller requested a motion to limit debate to two minutes per person for debate on submitted motions. *Motion submitted, seconded, and approved.*

2015 Annual Meeting Minutes: Commodore Miller requested membership's approval of the submitted 2015 Annual Meeting Minutes. *No objections noted. Minutes Approved.*

Appointment of Annual Meeting Minutes Approval Committee: Per Robert's Rules of Order, the club's parliamentarian expert recommended a committee to approve the Club's annual meeting minutes. *The Chair appoints the WVSC Board of Governors to approve the minutes of the annual meeting.* There is no change to the meeting minutes publication in the *Windword*.

Board of Governors Election: The nominations committee presented two nominees for the Board of Governors election: Deann Gadalla and Charlie Volk. Note a third nominee chose to withdraw. Commodore Miller then invited nominees from the floor. There were no nominations from the floor. Since there were three or fewer nominees for the three vacancies, the By Laws do not require a ballot vote. *The chair requested a vote to elect by show of hands. The meeting voted unanimously to elect Deann Gadalla and Charlie Volk to the club's 2017 Board of Governors.*

Congratulations to the WVSC's Board of Governors newly elected members:

Deann Gadalla and Charlie Volk – Welcome Aboard!

Procedure in the event the board is not filled: There is no procedure of record in the event the club does not fill all board vacancies at the annual meeting. *Commodore Miller submitted a motion to authorize the Board of Governors to fill the vacancy following the annual meeting, in the same way as if the vacancy were created by a resignation. Motion Carried. The Board of Governors is authorized to fill the vacant Board position.*

Committee Reports: The Committee chairs submitted written reports for the Annual Meeting and were distributed to the club membership (See reference 1). The minutes reflect items highlighted or added to the submitted written reports by the Committee Chairs.

Awards Committee: Commodore Miller reminded us that our sailing club is club of volunteers, and thanked those in attendance who have volunteered over the past year. Ed Webb presented the following 2016 WVSC awards:

Commodore Award – Tim Miller

Bosun’s Mess Award – Gary Mackey

Congeniality Award – Gene Plehal

Officer’s Mess Award – John Trumpower

Sportsmanship Award – Ernie Condon

Outstanding Service Award – Randy Malcom

Commodore Miller then presented the Commodore’s Award to Jenn Pasternak

Congratulations to our club’s volunteers – well deserved!

Membership Committee: Ardie Condon thanked her volunteers, Janet Van Eps, Nicki Rinker, Steve and Genee Kubin, David and Gwynne Bonifield

Sailing Activities Committee: Ernie Condon thanked his team of volunteers, including Gary Mackey, Gene Nold, Sid Rousseau, and Dave Barker.

Racing Committee: Rob Brown highlighted our 2016 racing season, reporting that we had a large number of boats out on the water this season, with 148 boat starts over 29 races. Ernie Condon led the participation, competing in all but one race. The 2016 Racing Awards:

Weekend Series

1 st Place	G^2	Gene Nold, Gary Pierce
2 nd Place	Dragon Fly	Rob Brown, Ginger Brown
3 rd Place	Need for Speed	Ernie Condon, Ardie Condon

Wednesday Night Series

1 st Place	About Time	Alan Loehr, Amos Cape, Jim Smith, Bart Peace
2 nd Place	Dragon Fly	Rob Brown, Ginger Brown
3 rd Place (tie)	Need for Speed	Ernie Condon, Ardie Condon
	Breezin'	Blaine Van Dam

Club Championship

1 st Place	Dragonfly	Rob Brown, Ginger Brown
2 nd Place	Need for Speed	Ernie Condon, Ardie Condon

Activity Center: Randy Malcom reported the center's exterior siding replacement is complete. Randy recommends the Club fully inspect the condition of the exterior carefully each season to catch needed maintenance early.

Security: Brian Hakala – Report submitted.

Social Committee: Brian Hakala thanked all of our club's volunteers who helped make our socials successful.

Calling Committee: Tim Miller thanked Julie Barth and her team of volunteers for their support. The volunteers are recognized in the submitted report.

Club Powerboat Maintenance: Gary Mackey and Ed Webb – report submitted. Gary did add that the powerboat is in great shape, and that it will be good opportunity for a club member to step up next year and take over the powerboat duties from Gary.

Building & Grounds & Dry Storage: John McCabe reminded members of our responsibility to keep our trailers "mobile" and labeled. John is still finding unmarked trailers, and trailers that are not ready to be moved, hindering his team's efforts in putting down new gravel.

- **Boat Hoist Feasibility Proposal Presentation by Jim Smith (See reference 2):** Jim presented a concept proposal for buying and installing a boat hoist for our club. The proposed location is in the dry storage area, on the west side of the storage building. The hoist will be capable of lifting up to 15, 000 lbs, more than sufficient to lift any of our club member's boats. The value of the hoist to club members include bottom work, keel maintenance (including lifting keels), boat trailer work and boat/trailer alignment. No specific cost estimates are available, as there are numerous options to explore prior to determining an accurate estimate. In parallel, the Club will need

to work the appropriate government approvals to authorize the installation on the site. Jim answered many questions from our club members. The presentation is attached. [Reference 2].

Action: Commodore Miller submitted a motion to assign the development of an engineering and financial plan for the hoist, to a committee consisting of Jim Smith, the Dry Storage Committee Chair, and the Government Relations Chair. The Committee will report out to the BOG by June 2017. *Motion Approved.*

Harbor Committee: Gene Nold added that the Club will need to continue to replace the floats on the docks, as some areas are floating lower than desired.

Government Relations Liaison: Gene Nold – report submitted.

Public Relations Committee: Cheryl Wertheimer highlighted the Club's efforts this past year for public relations, including the WVSC booth at the Wichita Women's Fair in February. Cheryl also led a discussion on potential changes to the format for the Windword that could lower our monthly costs.

Archive: David Reynolds – Report Submitted.

Safety, Training and Education Program (STEP): Deann Gadalla covered the highlights of the submitted report, and thanked the countless club volunteers that supported our STEP program this summer. Deann also informed the club that the WVSC STEP program is now a registered non-profit organization with Dillons, and that club members can sign up to support our STEP program with each purchase of Dillon's groceries. The sign up is quick and easy on line, and the credits do not impact your "fuel points" that you may already receive. You will see more information on how to sign up. This is an opportunity for our club members to help support our STEP program.

Financial Reports 2016:

WVSC Club Financial Report: Kathy Malcom briefed the 2016 budget status. The complete report is attached in the member handout. Kathy did highlight that our Club's reserves are in solid shape, and now able to handle our insurance deductible in the event of a major loss.

STEP Financial Report: Gene Nold presented the 2016 STEP budget report. The complete report is attached in the member handout.

Long Range Planning Committee Report: Ginger Brown presented the findings of the Committee that identified five major areas that will require Club expenditures over the

upcoming years, including the parking area resurfacing, activity center roof, dock maintenance including boards and floatation, the electrical system on the docks, and the dry storage area.

2017 Proposed Budgets:

2017 STEP Budget: Gene Nold presented the proposed 2017 budget for STEP. The complete proposal is in the member handout. *Motion to approve the 2017 STEP budget. Motion approved.*

2017 WVSC Budget: Brad Oblak presented the proposed 2017 budget for STEP. The complete proposal is in the member handout. *Motion to approve the 2017 WVSC budget. Motion approved.*

New Business: Boat Hoist concept exploration covered under Dry Storage section

Next Board of Governors Meeting: Commodore Miller reminded the club that the board organizational meeting is Thurs, 10 Nov, at Cabela's in Wichita.

Adjournment: The meeting was adjourned at 8:17 pm.